

DE SUNDIAL PRIMER

Equatorial Sundial
Northern Hemisphere

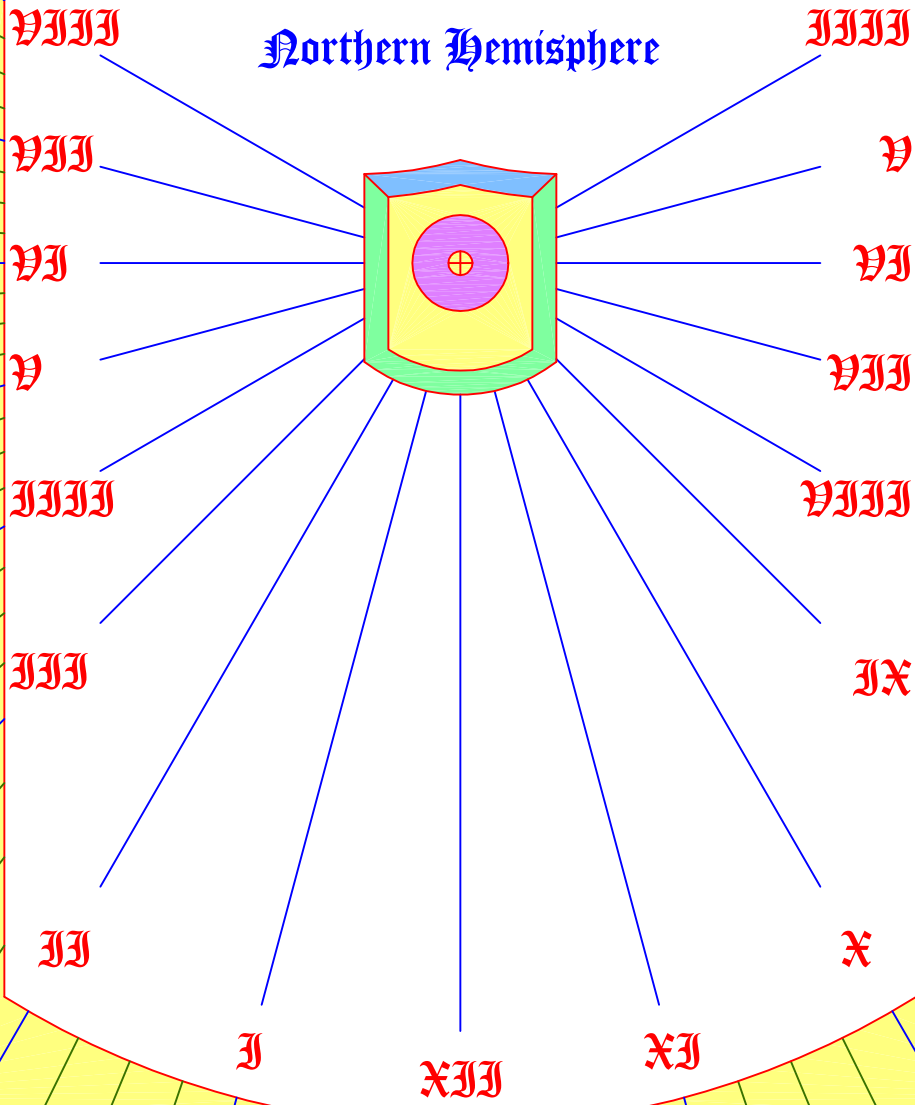

9

8

7

6

5

4

3

2

1

12

11

5

6

7

8

9

10

+ 60 45 30 15 0 15 30 45 60 -

DE SUNDIAL PRIMER

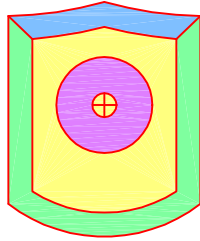

Equatorial Sundial

Northern Hemisphere

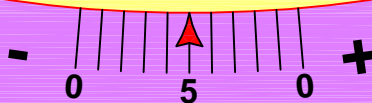

DE SUNDIAL PRIMER

Equatorial Sundial
Southern Hemisphere

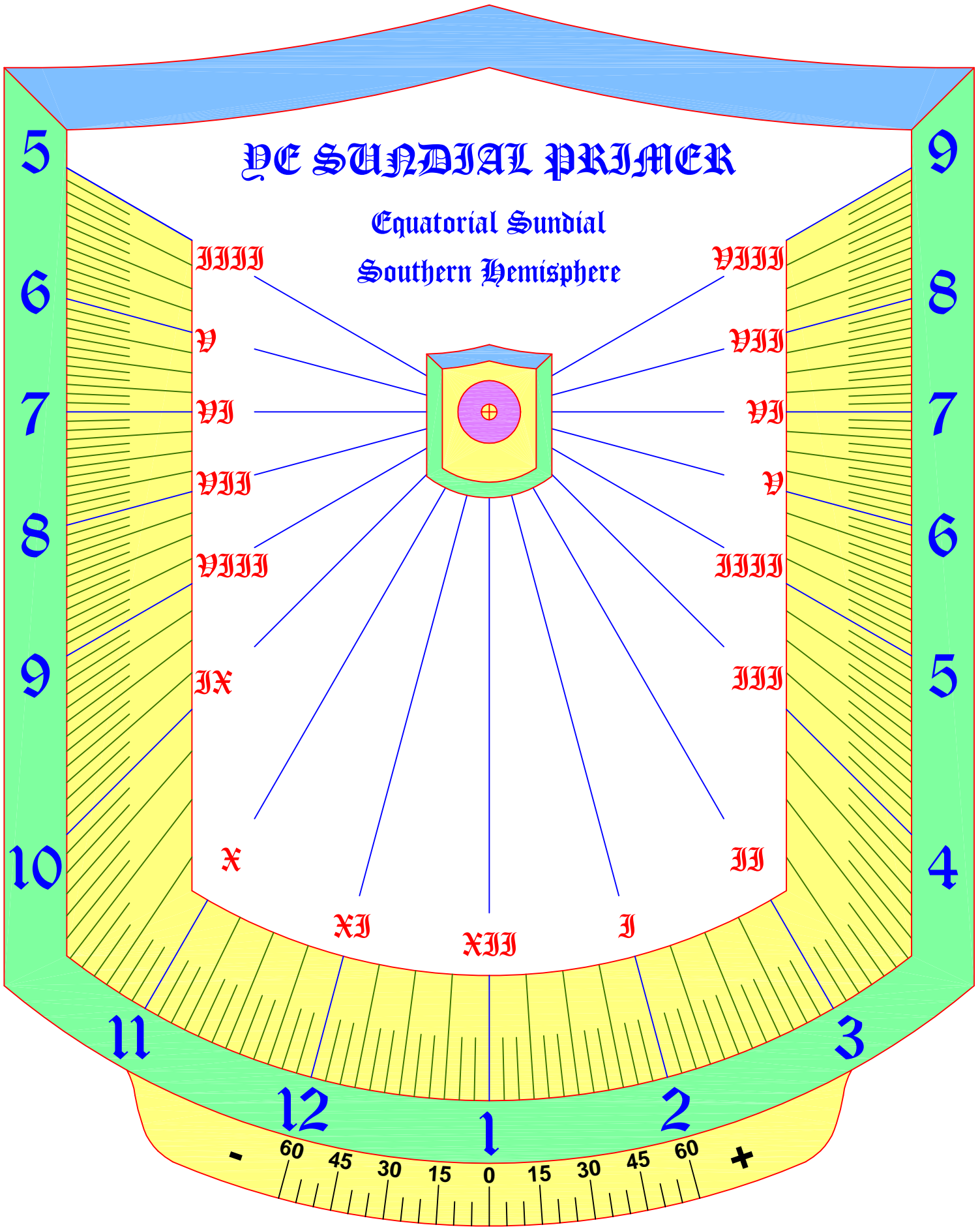

DE SUNDIAL PRIMER

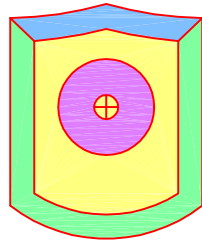

Equatorial Sundial

Southern Hemisphere

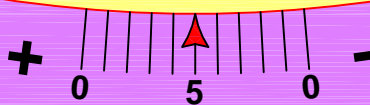

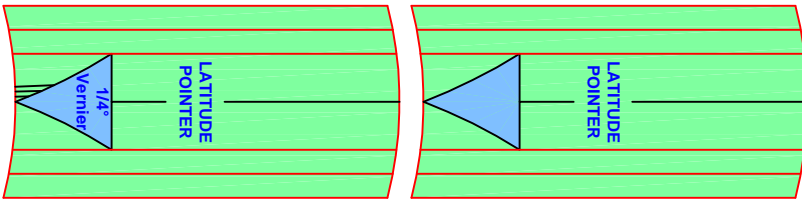

Part B - 1 required using the right template. Trim to thickness of dial plates. Choose 1 template & glue as shown in figure. The left template will allow the latitude to be set to 1/4° using the vernier instead of estimating. Make additional parts to make a 1" spacer as shown in figure.

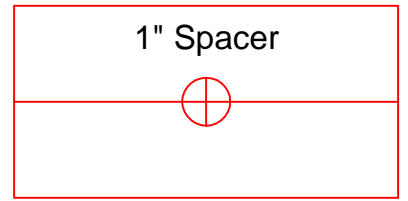

Cut out and place 1" spacers as shown in figure. This provides room for dial plate to rotate.

Part C - 2 required. This part includes Part D. Glued as a base between the bottoms of the 2 Part As.

Part D - 2 required. Cut this template out after making Part C. Used to widen the base.

This vernier will help to determine the time more accurately but can only be used on the circular portion of the dial plate.

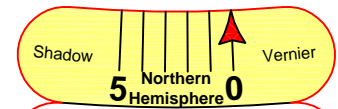

Align "0" with the shadow on the outer hour ring. Find vernier line closest to an hour line. Add the indicated minutes: 0 to 5.

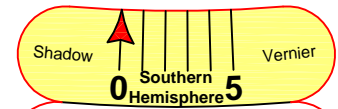

Align "0" with the shadow on the outer hour ring. Find vernier line closest to an hour line. Add the indicated minutes: 0 to 5.

Part A - 2 required. Save template & glue as shown in figure.

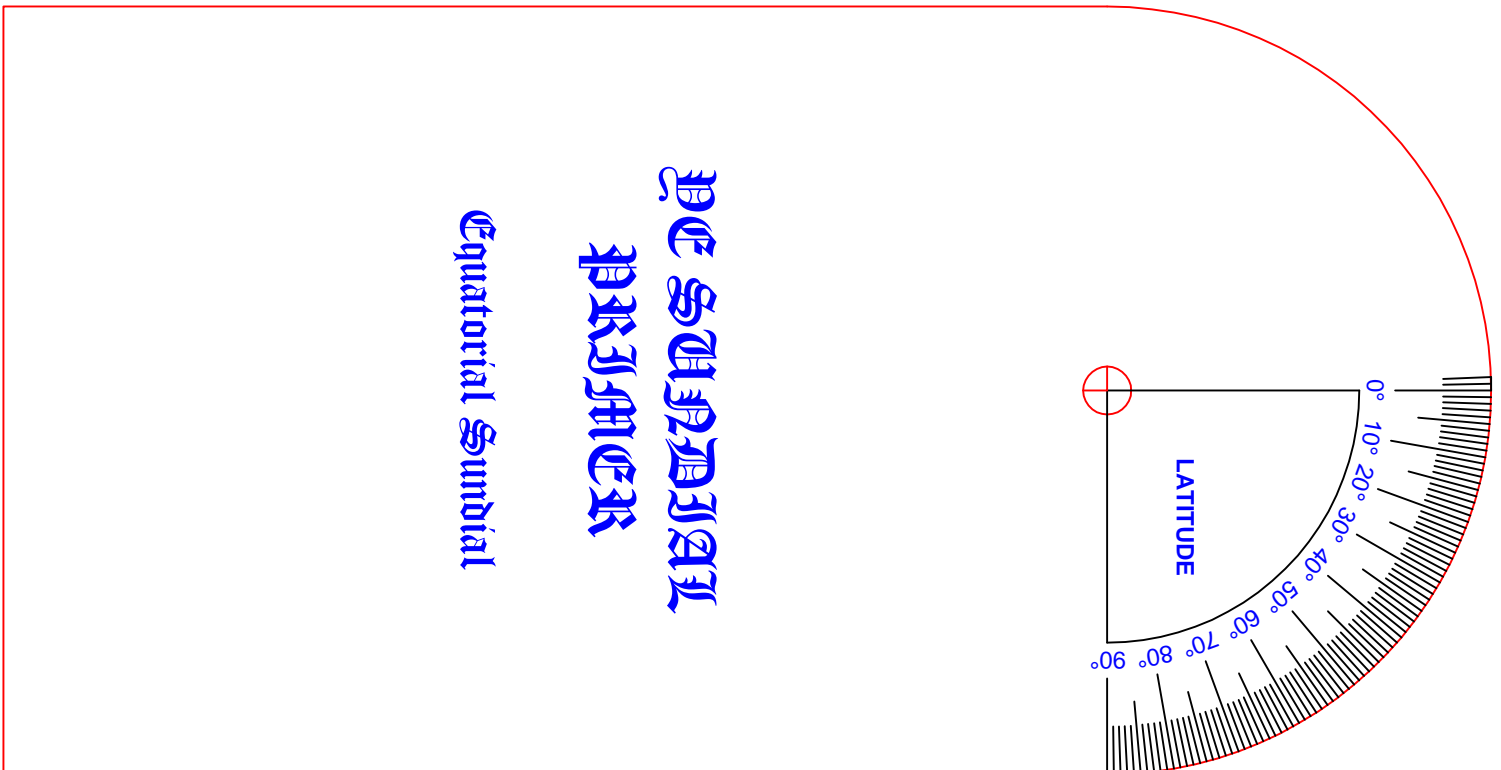

Front view of the sundial. For the Northern Hemisphere the top plate will be the "Northern Hemisphere" and for the Southern Hemisphere the top plate will be the "Southern Hemisphere". The "Latitude" scale and the "Latitude Pointer" must be placed on the right side as shown in the figure.

Pivot rod goes between the two back plates and along a line joining the two arrows.

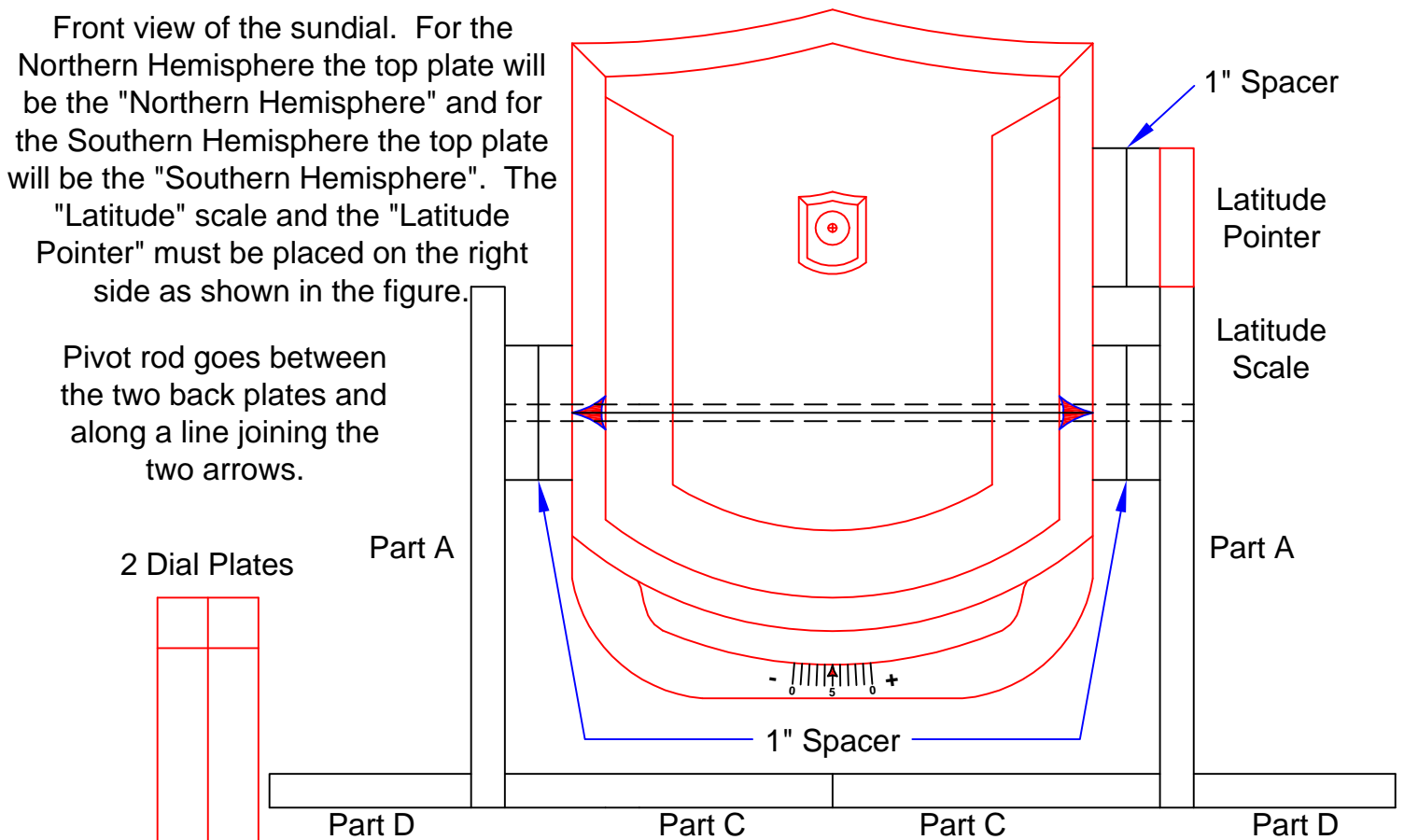

Use the arrows to mark the line on the back of the plates to indicate where the pivot rod is located. This line is 3/4" inch below the centre of the dowel. Score the line on both plates with a knife and cut out a groove for the rod to fit in. Set the rod in before gluing the two back plates together. This will help to give the plates a tight fit.

The pivot hole passes through the 2 Part As and between the 2 plates. Use a 12 inch long threaded rod, washers and wing nuts to create the pivot.

Glue the two back plates on to a flat and rigid surface, for example styrofoam or wood. Drill the 1/2" hole located in the small shields. Glue the two back plates together making sure they are properly aligned. Insert a section of 1/2" wood dowel so it extends 1/4" beyond the plate surfaces. The top plates will rotate around the dowel. Drill a perpendicular hole through the centre of the dowel the same diameter as the gnomon. The wire from a clothes hanger is quite stiff and will make a good gnomon.

Add weight to the base if it is unstable.

